

NE58F9500SS

5.8 cu. ft. Slide-in Electric Range

Features

- Premium Slide-in Design
- Five Electric Cooktop Elements, including Two Dual Burners
- Glass Touch Controls with Guiding Light System
- Dual Convection for Even Cooking
- Temperature Probe Ensures Best Cooking Results
- Large Oven Capacity: 5.8 cu. ft.
- Storage Drawer
- ADA Compliant

Convenience

- Self + Steam Clean
- Hot Surface Indicator Lights
- Auto Oven Light
- Proofing
- Sabbath Mode
- Kitchen Timer
- Delay Start
- Auto Shut-Off Option
- Child Safety Lock
- 5 Healthy Cook Presets



ADA Compliant



Five-Burner Cooktop



Guiding Light Controls

Available Colors



Stainless Steel (shown)



Black Stainless

Signature Features

GET A SLEEK, CUSTOMIZED, BUILT-IN LOOK FOR YOUR KITCHEN

- Sleek, slide-in design appears customized with cabinetry.
- Get a high-end look for your kitchen without having to remodel.
- Install easily and replace your freestanding range.

PREMIUM DESIGN WITH ILLUMINATED CONTROLS

- Intuitive controls offer simple, step-by-step instructions for choosing cooking options.
- Only illuminates cooking options that are able to be selected and goes from left to right eliminating back and forth.
- Control temperature and time settings, select cooking functions and program your favorite recipes.

EXTRA-LARGE OVEN ALLOWS YOU TO COOK MULTIPLE DISHES AT ONCE

- 5.8 cu. ft. easily accommodates a big roast, multiple casserole dishes or several racks of cookies.
- Three oven racks so you can prepare enough food for large gatherings.
- Largest-capacity slide-in range.¹

¹As of March 2013.

SAMSUNG

NE58F9500SS

5.8 cu. ft. Slide-in Electric Range

Installing Your Range

*30" minimum clearance between the top of the cooking surface and the bottom of an unprotected wood or metal cabinet; or 24" minimum when the bottom of the wood or metal cabinet is protected by not less than 1/4" flame-retardant millboard covered with not less than no. 28 MSG sheet steel, 0.015" stainless steel, 0.024" aluminum or 0.020" copper.

** 18" minimum between the countertop and the adjacent cabinet bottom.

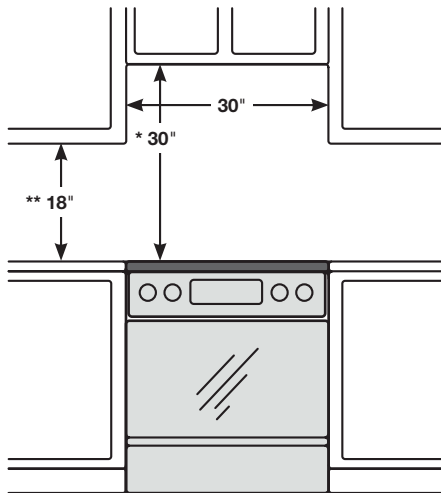

IMPORTANT: To eliminate the risk of burns or fire caused by reaching over heated surface units, cabinet storage space located above the surface units should be avoided. If cabinet storage is to be provided, the risk can be reduced by installing a range hood that projects horizontally a minimum of 5" beyond the bottom of the cabinets.

Dimensions

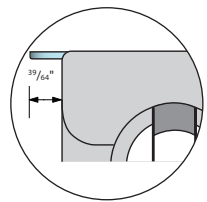
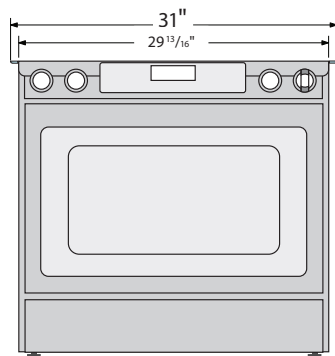

Glass cooktop overlaps and sits on top of your kitchen countertop to give a built-in look. Cutout space for the range is 29^{13/16}".

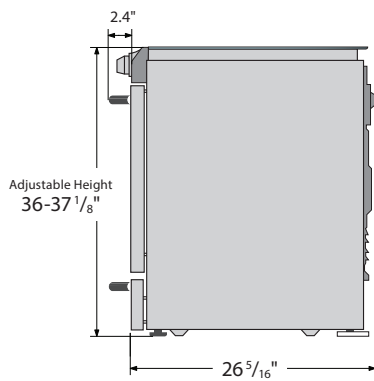

Electric Ceramic Cooktop

- Right Front: 9/12", 3.0 kW
- Left Front: 6/9", 3.0 kW
- Right Rear: 6", 1.2 kW
- Left Rear: 6", 1.2 kW
- Center: 100 W

Oven

- Hidden Bake Element: 3000 W
- Bake: 175°F-550°F
- Convection Bake: 175°F-550°F
- Convection Roast: 175°F-550°F
- Variable Broil (Low - High)
- Convection Element/Heater: 1250 W
- Proofing
- Sabbath Mode
- Storage Drawer Capacity – 0.7 cu. ft.

Warranty

- One (1) Year All Parts and Labor
- Five (5) Years Electric Cooktop

Product Dimensions & Weight (WxHxD)

Outside Dimensions:
31" x 36-37^{1/8}" (Adjustable) x 26^{5/16}"

Weight: 191.8 lbs.

Shipping Dimensions & Weight (WxHxD)

Dimensions:
33^{1/16}" x 41^{3/4}" x 30^{5/16}"

Weight: 216 lbs.

Color	Model #	UPC Code
Stainless Steel	NE58F9500SS	887276988191
Black Stainless Steel	NE58K9500SG	887276142876

SAMSUNG

Actual color may vary. Design, specifications, and color availability are subject to change without notice. Non-metric weights and measurements are approximate.

©2016 Samsung Electronics America, Inc. 85 Challenger Road, Ridgefield Park, NJ 07660. Tel: 800-SAMSUNG. samsung.com. Samsung is a registered trademark of Samsung Electronics Co. Ltd.