

# RF28NDEDBSG

SAMSUNG

## Samsung 28 cu. ft. 3-Door French Door Food Showcase Refrigerator



### Signature Features

#### Food Showcase Fridge Door

- Food ShowCase Door gives you easy reach of key items that are most often used, all visible in one glance.

#### Metal Cooling

- Locks in cold, seals in freshness.
- Stainless steel paneling helps maintain consistent temperature throughout the refrigerator.

#### Large Capacity

- Our 28 cu. ft. large-capacity Four-Door French Door has enough room to fit up to 28 bags of groceries.\*

\*Grocery comparison based on each cubic foot of usable space equaling one paper bag.

### Available Color



Fingerprint Resistant  
Black Stainless Steel



Food Showcase Fridge Door



Metal Cooling

### Features

- Food Showcase Fridge Door
- Metal Cooling
- Large Capacity – 28 cu. ft.
- Twin Cooling Plus®
- Ice Master Ice Maker in the Refrigerator
- ENERGY STAR®-Compliant
- CoolSelect Pantry™ with Temperature Control
- External Filtered Water and Ice Dispenser
- High-Efficiency Top and Side LED Lighting
- Power Freeze and Power Cool Options
- EZ-Open Handle™ on Freezer Door

- Two Humidity-Controlled Crispers
- Tempered Glass Spill-Proof Shelves
- Pantry Divider

### Convenience

- CoolTight Door
- Door Alarm
- Water Filter Indicator

### Rating



ENERGY STAR®-rated:  
CEE Tier 3  
651 kWh/yr

# RF28NDEDBSG

# SAMSUNG

## Samsung 28 cu. ft. 3-Door French Door Food Showcase Refrigerator

### Installation Specifications

1. Measure the height, width and depth of the opening, making sure to include baseboards, molding tile, countertop overhang, etc. Check to be sure there is enough room to open the door (consider walls, islands or other obstacles when measuring).
2. Refer to illustration below to determine dimensions.
3. Allow 2.5" of clearance on hinge side of refrigerator when installing next to a wall where handle may make contact.
4. Allow 1" minimum clearance at rear for proper air circulation and water/electrical connections. Allow a 3/8" minimum clearance at sides and top for ease of installation.
5. Ensure each door and entryway in the home is wide enough for the refrigerator to be moved through easily.

For optimal usage and to be able to open refrigerator doors completely, do not install next to a wall.

Please note: The following dimension and cutout information is for planning purposes only. For complete installation details, consult manual packed with product, or download manual online at [samsung.com](http://samsung.com).



### Dimensions

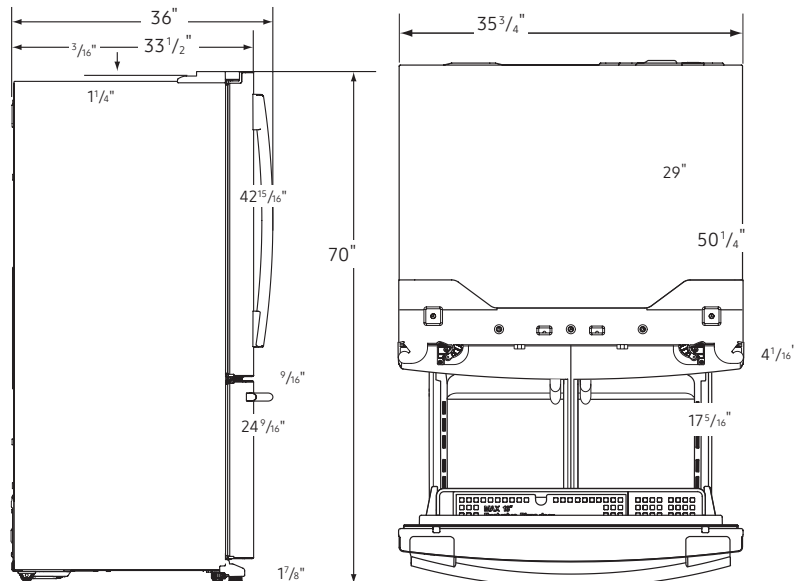

**Total Capacity: 27.8 cu. ft.**

**Refrigerator: 18.9 cu. ft.**

- Food Showcase Fridge Door
- Premium External Filtered Water and Ice Dispenser
- Ice Master Ice Maker
- CoolSelect Pantry™ with Temperature Control – Deli (41°C), Fresh (38°F) and Chilled (32°F) options
- Pantry Divider
- 2 Humidity-Controlled Crispers
- 5 Tempered Glass Spill-Proof Shelves:
  - 1 Slide-In, 1 Slide-Out, 1 Foldable Half, 2 Fixed
- 8 Clear Door Bins
  - Right Door: 2 Gallon Bins, 2 Regular Bins, 1 Dairy Bin
  - Left Door: 3 Regular Bins
- High-Efficiency Top and Side LED Lighting

**Freezer: 8.9 cu. ft.**

- EZ-Open Handle™
- High-Efficiency LED Lighting

### Warranty

One (1) Year Parts and Labor on Refrigerator  
Five (5) Years Parts and Labor on Sealed Refrigeration System Only\*  
Ten (10) Years Parts and Five (5) Years Labor on Digital Inverter Compressor

\*Compressor, evaporator, condenser, drier and connecting tubing.

### Product Dimensions & Weight

Dimensions (WxHxD with hinges, handles and doors):  
35 3/4" x 70" x 36"

Dimensions (WxHxD without hinges and door):  
35 3/4" x 68 7/8" x 29"

Dimensions (WxHxD with hinge and door, no handle):  
35 3/4" x 70" x 33 1/2"

Weight: 370.4 lbs.

### Shipping Dimensions & Weight (WxHxD)

Dimensions: 38 5/8" x 76 5/8" x 36 1/4"

Weight: 396.8 lbs.

Color	Model #	UPC Code
Fingerprint Resistant Black Stainless Steel	RF28NDEDBSG	887276279947