

RS25H5121SR

24.5 cu. ft. Side-by-Side Refrigerator

Features

- Large Capacity – 24.5 cu. ft.
- External Filtered Water and Ice Dispenser
- CoolSelect Zone™ Drawer
- Twin Cooling Plus®
- ENERGY STAR®-Compliant
- In-Door Ice Maker
- LED Tower Lighting
- Multi Air Flow
- Power Freeze and Power Cool Options
- Tempered Glass Spill-Proof Shelves
- Gallon Door Bins

Convenience

- Door Alarm
- Water Filter Indicator



ENERGY STAR®-rated: CEE Tier 1
(11% more efficient than Federal Standard)
634 kWh/yr



Side-by-Side Design

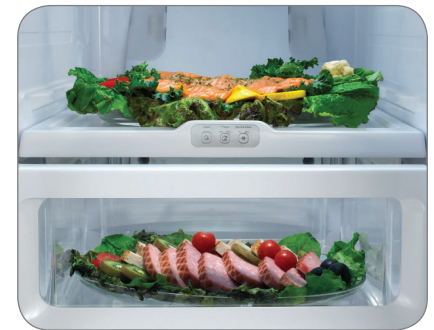

CoolSelect Zone™

Available Colors



Stainless Steel



White

Signature Features

COOLSELECT ZONE™ DRAWER

- CoolSelect Zone™ provides additional temperature control for your food storage needs with Quick Cool, Thaw and Cool Mode options.

TWIN COOLING PLUS®

- Keeps food fresher longer – Twin Cooling Plus® humidity levels up to 3.6x higher than single cooling.
- Refrigerator air is kept at higher, near-commercial-grade humidity levels to keep perishable fruits and vegetables fresher longer.
- Drier freezer air means less freezer burn for better-tasting frozen foods.

LED TOWER LIGHTING

- Our new strategically placed Tower lighting gently brightens every corner of your refrigerator while reducing heat and energy output. Its space-saving design leaves more room for groceries.

SAMSUNG

RS25H5121SR

24.5 cu. ft. Side-by-Side Refrigerator

Installing Your Refrigerator

1. Measure the height, width and depth of the opening, making sure to include baseboards, molding tile, countertop overhang, etc. Check to be sure there is enough room to open the door (consider walls, islands or other obstacles when measuring).
2. Refer to illustration below to determine dimensions.
3. Allow 2" of clearance on hinge side of refrigerator when installing next to a wall where handle may make contact.
4. Allow 1" minimum clearance at rear for proper air circulation and water/electrical connections. Allow a 3/8" minimum clearance at sides and top for ease of installation.
5. Ensure each door and entryway in the home is wide enough for the refrigerator to be moved through easily.

Please note: The following dimension and cutout information is for planning purposes only. For complete installation details consult manual packed with product, or download manual online at samsung.com.



Dimensions

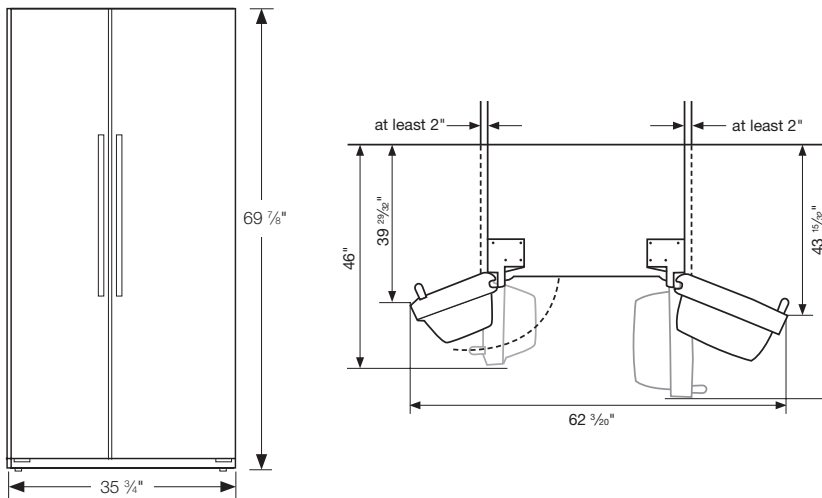

Total Capacity: 24.5 cu. ft.

Refrigerator: 15.32 cu. ft.

- Multi Air Flow
- CoolSelect Zone™
- 4 Tempered Glass Spill-Proof Shelves
- 2 Clear Crispers
- 1 Clear Drawer
- 5 Door Bins
 - 2 Gallon Bins
 - 2 Clear Bins
 - 1 Dairy Bin
- LED Tower Lighting

Freezer: 9.18 cu. ft.

- External Filtered Water and Ice Dispenser (Crushed or Cubed Ice)
- Automatic In-Door Ice Maker
- 4 Glass Shelves
- 3 Clear Door Bins
- 2 Clear Drawers
- LED Tower Lighting

Accessories

Water Filter: HAF-CIN

Warranty

One (1) Year Parts and Labor on Refrigerator

Five (5) Years Parts and Labor on Sealed Refrigeration System Only*

Ten (10) Years Parts and Five (5) Years Labor on Digital Inverter Compressor

*Compressor, evaporator, condenser, drier, connecting tubing.

Product Dimensions & Weight

Dimensions (WxHxD with hinges, handles and doors):
35³/₄" x 69⁷/₈" x 36¹/₂"

Dimensions (WxHxD without hinges and door):
35³/₄" x 68³/₅" x 29⁵/₈"

Dimensions (WxHxD with hinge and door, no handle):
35³/₄" x 69⁷/₈" x 33³/₄"

Weight: 278.8 lbs.

Shipping Dimensions & Weight (WxHxD)

Dimensions: 37³/₄" x 78⁷/₈" x 36¹/₄"

Weight: 286.6 lbs.

Color	Model #	UPC Code
Stainless Steel	RS25H5121SR	887276956107
White	RS25H5121WW	887276957210

SAMSUNG

Actual color may vary. Design, specifications, and color availability are subject to change without notice. Non-metric weights and measurements are approximate.

©2018 Samsung Electronics America, Inc. 85 Challenger Road, Ridgefield Park, NJ 07660. Tel: 800-SAMSUNG. samsung.com. Samsung is a registered trademark of Samsung Electronics Co. Ltd.