

RB10FSR4ESR

SAMSUNG

11.3 cu. ft. Bottom Freezer Refrigerator



Signature Features

24" Width

Slim width design to fit in smaller spaces while maximizing capacity without sacrificing style.

Fingerprint Resistant Finish

A finish that withstands everyday smudges, so you spend less time cleaning.

Recessed Handles

Recessed handles provide clean exterior design, easy access, and matches any kitchen appliance.

Available Color



Fingerprint Resistant
Stainless Steel (shown)



24" Width

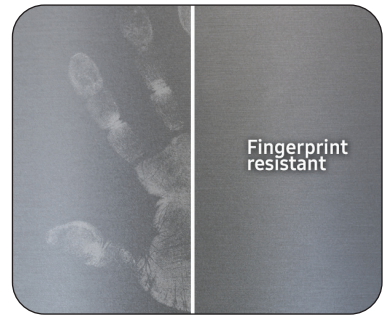

Fingerprint Resistant Finish

Design

- 24" Width
- Fingerprint Resistant Finish
- Recessed Handles
- High Efficiency LED Lighting
- Full Open Box Freezer
- Easy Slide Shelf

Performance

- All-Around Cooling

Rating



ENERGY STAR® rated:
390 kWh/yr

RB10FSR4ESR

SAMSUNG

11.3 cu. ft. Bottom Freezer Refrigerator

Installation Specifications

1. Measure the height, width and depth of the opening, making sure to include baseboards, molding tile, countertop overhang, etc. Check to be sure there is enough room to open the door (consider walls, islands or other obstacles when measuring).
2. Refer to illustration below to determine dimensions.
3. Allow 2.5" of clearance on hinge side of refrigerator when installing next to a wall where handle may make contact.
4. Allow 1" minimum clearance at rear for proper air circulation and water/electrical connections. Allow a 3/8" minimum clearance at sides and top for ease of installation.
5. Ensure each door and entryway in the home is wide enough for the refrigerator to be moved through easily.

For optimal usage and to be able to open refrigerator doors completely, do not install next to a wall.

Please note: The following dimension and cutout information is for planning purposes only. For complete installation details, consult manual packed with product, or download manual online at samsung.com.

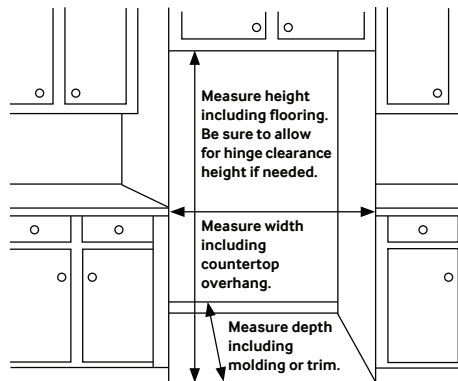

Dimensions

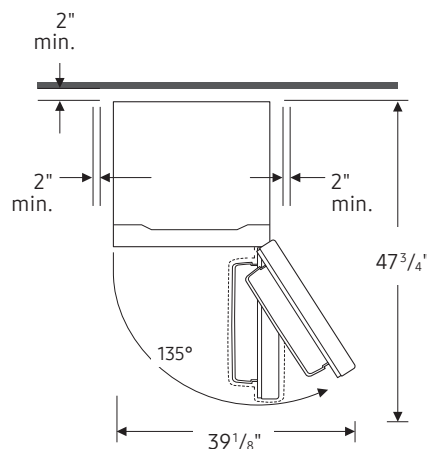
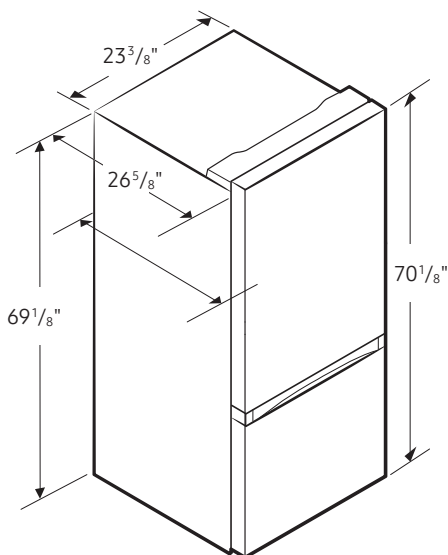

Total Capacity: 11.3 cu. ft.

Refrigerator: 7.5 cu. ft.

- 4 Tempered Glass Spill-Proof Shelves
- 1 Humidity-Controlled Crisper
- 4 Door Bins
 - 1 Gallon Bins, 3 Regular Bins
- High Efficiency LED Lighting

Freezer: 3.8 cu. ft.

- 3 Drawers

Warranty

One (1) Year Parts and Labor on Refrigerator

Five (5) Years Parts and Labor on

Sealed Refrigeration System Only*

Ten (10) Years Parts and Five (5) Years

Labor on Digital Inverter Compressor

*Compressor, evaporator, condenser, drier and connecting tubing.

Product Dimensions & Weight

Dimensions (WxHxD with hinges, handles and doors):
23³/₈" x 70¹/₈" x 26⁵/₈"

Dimensions (WxHxD without hinges and door):
23³/₈" x 69¹/₈" x 24³/₈"

Dimensions (WxHxD with hinge and door, no handle):
23³/₈" x 70¹/₈" x 26⁵/₈"

Weight: 139 lbs

Shipping Dimensions & Weight (WxHxD)

Dimensions: 25³/₄" x 73⁷/₈" x 27⁵/₈"

Weight: 152 lbs

Color

Fingerprint Resistant
Stainless Steel

Model

RB10FSR4ESR

UPC Code

887276390154