

ME21F707MJT

2.1 cu. ft. Over-the-Range Microwave

SAMSUNG



Signature Features

Precise Touch Control with a Premium Look

- Convenient location makes it easy to access cooking options.
- Glass control panel provides a seamless, integrated design.
- Design elements match (but are not limited to) the slide-in electric ranges.

Scratch-Resistant and Easy-to-Clean

- Durable ceramic enamel interior provides a polished surface that's easy to maintain.
- Effortlessly remove grease or oil from surfaces.
- Protects against scratches that occur from daily use.

Big Space for Big Results

- 2.1 cu. ft. inside accommodates large platters and dishes, which typically do not fit in the average, mid-size 1.5 cu. ft. microwave.
- A perfect option for large families.

Available Color



Fingerprint Resistant
Stainless Steel (shown)



One-Touch Simple Clean Filter



Ceramic Enamel Interior

Features

- 2.1 cu. ft. Capacity
- 1000 Watts of cooking power, with Sensor Cooking to heat food the correct amount of time
- LED Cooktop Light
- Ceramic Enamel Interior
- One-Touch Simple Clean Filter
- Eco Mode (reduces standby power)
- Cooking Control: 10 power levels including defrost and Sensor Cook options
- Rotating Glass Turntable
- Glass-Touch Bottom Controls
- 2-Line LCD Display
- 400 CFM Ventilation System

Convenience

- Kitchen Timer
- Clock (12hr/24hr) with Daylight Saving Time Adjustment
- Child Safety Lock
- Reminder End Signal
- Auto Night Light

ME21F707MJT

SAMSUNG

2.1 cu. ft. Over-the-Range Microwave

Dimensions

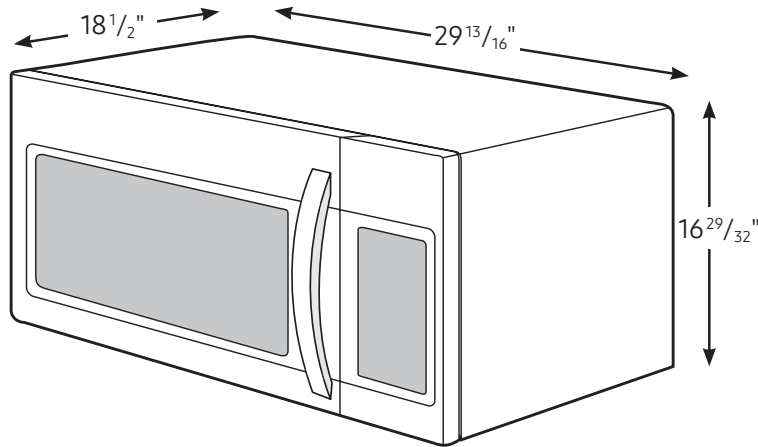

Installing Your Microwave

- This microwave oven is designed for adaptation to the following three types of ventilation:
 - A. Outside Top Exhaust (Vertical Duct)
 - B. Recirculating (Non-Vented Ductless)
 - C. Outside Back Exhaust (Horizontal Duct)
- The space between the cabinets must be 30" wide and free of obstructions.
- This microwave oven is for installation over ranges up to 36" wide.
- The microwave must be level. Use a level to make sure the cabinet bottom is level. If the cabinets have a front overhang only, with no back or side frame, install the mounting plate down the same distance as the front overhang depth. This will keep the microwave level.

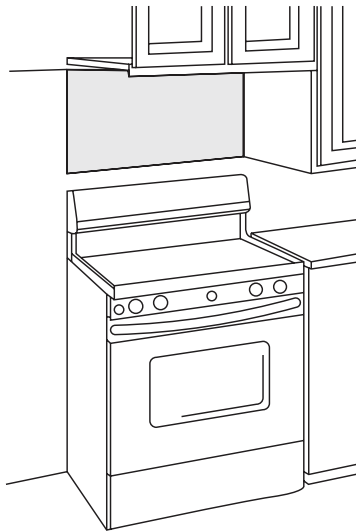

Specifications

- Oven Cavity: 2.1 cu. ft.
- Power Output: 1000W
- Power Consumption: 1700W/14.5 A
- Power Source: 120V/60 Hz
- Control Method: Glass-Touch Bottom Controls
- Display: 2-Line LCD
- Cooking Control: 10 Power Levels Including Defrost and Sensor Cook
- Microwave Distribution System: Turntable
- Vent Fan: 400 CFM
- Vent Fan Control: On/Off
- Cooktop Lighting: High/Low/Off

Warranty

One (1) Year All Parts and Labor
Ten (10) Years Parts on Magnetron

Product Dimensions & Weight (WxHxD)

Cavity Dimensions: 22 1/8" x 10 13/16" x 14 13/16"
Outside Net Dimensions: 29 13/16" x 16 29/32" x 18 1/2"
Weight: 58 lbs.

Shipping Dimensions & Weight (WxHxD)

Dimensions: 33 5/16" x 20 3/4" x 16 29/32"
Weight: 65 lbs.

Color

Fingerprint Resistant
Stainless Steel

Model

ME21F707MJT

UPC Code

887276981352

FOR EASIER INSTALLATION AND PERSONAL SAFETY, WE RECOMMEND THAT TWO PEOPLE INSTALL THIS MICROWAVE OVEN. IMPORTANT: Do not grip or use handle during installation.

NOTE: If your cabinet is metal, use the nylon grommet around the power cord hole to prevent cutting of the cord.

NOTE: We recommend using filler blocks if the cabinet front hangs below the cabinet bottom shelf.

IMPORTANT: If filler blocks are not used, case damage may occur from overtightening screws.

NOTE: When mounting the microwave oven, thread power cord through hole in bottom of top cabinet. Do not pinch cord or lift oven by pulling cord.