

RF20HFENBSR

SAMSUNG

Samsung 30" Wide 22 cu. ft. Capacity French Door Refrigerator



Signature Features

Automatic Filtered Ice Maker in Freezer

- Conveniently located in the freezer, Samsung's ice maker provides filtered ice cubes.

Twin Cooling System®

- Refrigerator air is kept at higher, near-commercial-grade humidity levels to keep perishable fruits and vegetables from spoiling quickly.*
- Drier freezer air means less freezer burn for better-tasting frozen foods.

* Twin Cooling® humidity levels up to 5x higher than single cooling systems.

LED Lighting

- Beautifully lights up the interior so you're able to quickly spot what you want.
- Sleek design saves more space than traditional incandescent light bulbs.

Available Colors



Stainless Steel (shown)



Fingerprint Resistant
Black Stainless Steel



White



French Door Design



High-Efficiency LED Lighting

Features

- 30" Wide
- Large Storage Capacity – 22 cu. ft. Capacity
- Ice Maker in Freezer
- High-Efficiency LED Lighting
- Wide open Pantry
- Two Humidity-Controlled Crispers
- Tempered Glass Spill-Proof Shelves
- Auto Pull-Out Upper Freezer Drawer

Convenience

- CoolTight Door
- Door Alarm
- Removable Ice Caddy

Rating

Meets DOE Standards:
630 kWh/yr

RF20HFENBSR

SAMSUNG

Samsung 30" Wide 22 cu. ft. Capacity French Door Refrigerator

Installation Specifications

1. Measure the height, width and depth of the opening, making sure to include baseboards, molding tile, countertop overhang, etc. Check to be sure there is enough room to open the door (consider walls, islands or other obstacles when measuring).
2. Refer to illustration below to determine dimensions.
3. Allow 2.5" of clearance on hinge side of refrigerator when installing next to a wall where handle may make contact.
4. Allow 1" minimum clearance at rear for proper air circulation and water/electrical connections. Allow a 3/8" minimum clearance at sides and top for ease of installation.
5. Ensure each door and entryway in the home is wide enough for the refrigerator to be moved through easily.

For optimal usage and to be able to open refrigerator doors completely, do not install next to a wall.

Please note: The following dimension and cutout information is for planning purposes only. For complete installation details, consult manual packed with product, or download manual online at samsung.com.

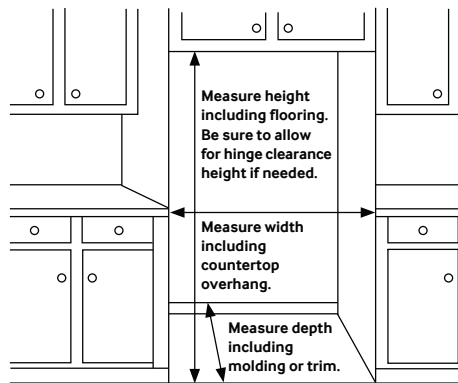

Dimensions

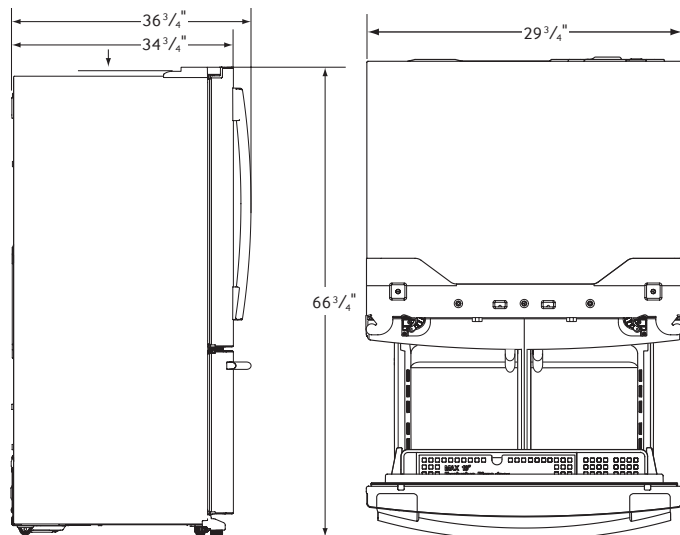

Total Capacity: 21.8 cu. ft.

Refrigerator: 14.8 cu. ft.

- Wide Open Pantry
- 2 Humidity-Controlled Crispers
- 5 Tempered Glass Spill-Proof Shelves
- 6 Gallon Door Bins
- High-Efficiency LED Lighting

Freezer: 7.0 cu. ft.

- 1 Large Opaque Freezer Bin with Divider
- Auto Pull-Out Upper Drawer Bin
- Ice Maker (Cubed)
- High-Efficiency LED Lighting

Accessories

External Filter (not included)

Warranty

One (1) Year Parts and Labor on Refrigerator
Five (5) Years Parts and Labor on Sealed Refrigeration System Only*
Ten (10) Years Parts and Five (5) Years Labor on Digital Inverter Compressor

*Compressor, evaporator, condenser, drier and connecting tubing.

Product Dimensions & Weight

Dimensions (WxHxD with hinges, handles and doors):
29 3/4" x 66 3/4" x 36 1/4"

Dimensions (WxHxD without hinges and door):
29 3/4" x 65 3/8" x 30 1/2"

Dimensions (WxHxD with hinge and door, no handle):
29 3/4" x 66 3/4" x 33 7/8"

Weight: 251.3 lbs.

Shipping Dimensions & Weight (WxHxD)

Dimensions: 31 7/8" x 74 3/4" x 36 1/4"

Weight: 275.6 lbs.

Color	Model #	UPC Code
Stainless Steel	RF220NCTASR	036725590250
Fingerprint Resistant Black Stainless Steel	RF220NCTASG	887276174693
White	RF220NCTAWW	036725590281